

# IoT Based Patient Health Monitoring using ESP8266 and Arduino

<sup>1</sup>Dr. P. Venkata kishore, <sup>2</sup>P Sarala, <sup>3</sup>M Dilip Kumar, <sup>4</sup>B. Bhaskar Reddy,  
Professor<sup>1,4</sup>, Assoc Prof<sup>2,3</sup>

EEE Department, Guru Nanak Institutions and Technical Campus, Hyderabad., pvkishorehod@gmail.com  
, Dept of EEE, Sri Indu College of Engineering and Technology., sarala.2906@gmail.com  
Assoc Prof, Dept of EEE, Nalla Malla Reddy Engineering College., manikdilig@gmail.com  
Dept. of ECE, Bheema Institute of Technology and Sciences, Adoni-518301.bhaskar.reddy876@gmail.com



## Keywords:

Words and phrases like "Internet of Things," "ESP8266," "Arduino," "Biomedical Sensors," and "Thing speak"

## Abstract:

The Internet of Things represents a new paradigm in information technology that may be adapted for use in continuous patient monitoring. Physiological characteristics such as heart rate and body temperature are monitored in real time using biomedical sensors and microcontroller, and this article reviews and details the implementation of this technique. Using a prototype Internet of Things platform, this device may monitor vital signs and provide real-time updates.



This work is licensed under a Creative Commons Attribution Non-Commercial 4.0 International License.

## Introduction

Today's hospital patient monitoring systems allow for round-the-clock tracking of vitals, but they need sensors to be connected to nearby monitors or personal computers, thereby limiting the patient's mobility while in care. A paramedical assistant's work doesn't end when he or she has attached such devices to a patient. It is possible to continuously monitor and record a patient's vitals by keeping track of all of their relevant data [1, 2]. Critical care now routinely includes continuous monitoring of vital signs, including heart rate, breathing rate, blood pressure, and oxygen saturation [3]. When displaying and analysing physiological data in a timely manner is essential, electronic monitors are often used. [4] It was proposed to use wireless technology based on an active network, with a sensor-microcontroller module in charge of monitoring the health of many individuals simultaneously. The total number of ICU patients. In terms of price, the aforementioned prototype was ideal. It was suggested in Jimenez et al. [5] that an E-health sensor safeguard pack interface unit be used in conjunction with a web-based monitoring framework to allow loved ones and medical professionals to keep tabs on a patient's condition while they were away from the emergency room.

However, it does not provide any kind of notice, including email and SMS alert, to particular family members and medical professionals. The authors of Krishnan et al. [6] considered monitoring a patient's condition and alerting doctors and loved ones to any changes. According to [7], with the Internet of Things present, the medical services division may monitor the whereabouts of all types of patients, collect patient information, and transmit this data remotely. Transmission of information must be kept private if this relationship is to continue. This technology is designed with effective and various communication concepts to implement IoT in the medical services office. An asset-based information recovery technique is offered as a means of keeping up with data-intensive wellness applications. This technology is integrated with a smart box, which is seen as a clinical framework, to monitor and manage patients' activities. Web real-time communication is properly executed to increase data transfer safety. With the goal of providing a non-invasive technique, Banerjee et al. [8] suggested a heart rate recognition framework. The suggested framework used a plethysmography method and clearly

displayed the results, turning it into a constantly monitoring instrument. Compared to more intrusive treatments, this one has shown to be reliable for the patient. In this work, we show how the Internet of Things can be used to build a patient health monitoring system by integrating ESP8266 and Arduino to acquire vital signs like heart rate and temperature in real time.

## There is already a body of literature

The steps required to create a prototype of a low-cost modular monitoring system are detailed in Sarmah et al. [9]. With the goal of facilitating more effective and timely medical responses during times of crisis, this system was developed using low-power sensor arrays for electrocardiogram (ECG), oxygen saturation (SpO<sub>2</sub>), temperature, and motion[9]. These sensors' interfaces were developed with the IoT architecture in mind: a centralised control unit exposes a RESTful based Web interface that guarantees platform-independent behaviour and offers a flexible method for adding additional components[9]. The prototype was costly per unit and cumbersome to implement. Yew et al. [10] emphasised the need of patient monitoring in today's medical facilities and at-home care settings. By combining data from a variety of sensors, the intelligent patient monitoring system shown here can keep tabs on a patient's health without the need for human intervention. After being processed on a Raspberry Pi, the data is subsequently uploaded to the IoT cloud. An electrocardiogram (ECG) sensor would be used as the system's main component for extracting the bio signal [10]. This method uses a raspberry-pi microcontroller to continuously monitor and display graphical representations of the patient's data, however it comes at a high cost. The primary objective of the study's IoT-based healthcare system was to increase patient satisfaction by allowing for continuous monitoring of vital signs including systolic and diastolic blood pressure, pulse rate, and core body temperature [11]. The primary idea is to provide care by continuously monitoring medical parameters like blood pressure, pulse rate, and body temperature without requiring the patient to go from facility to facility for constant health monitoring[11]. Data is collected from blood pressure and temperature sensors, evaluated, and saved in the cloud, where it can be monitored by the patient's caretakers from anywhere, and appropriately responded to base on the alarm recipients. It was difficult to instal the prototype, and it was also costly to keep running.

## Plan for a Prototype Block Diagram

Figure 1 shows a simple block diagram of the Internet of Things based Patient Health Monitoring System built using ESP8266 and Arduino.

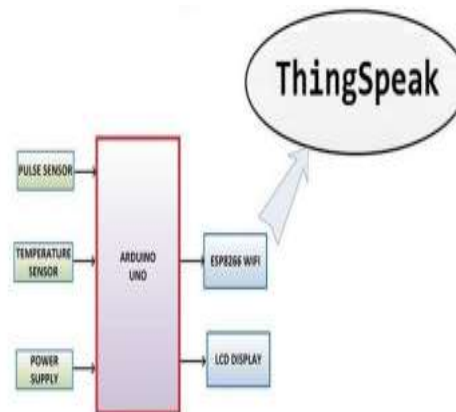

Figure 1. Proposed Prototype Block Diagram[6]

## Hardware Equipment

### Pulse Sensor

The Pulse Sensor is an Arduino-compatible heart-rate sensor. Students, artists, athletes, and game and smartphone developers who wish to incorporate live heart-rate data into their work can make an application of it [11].

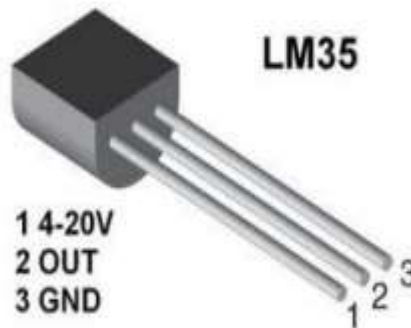

*Figure 2. Pulse Sensor*

The system's brains are an integrated optical amplification circuit and a noise-reducing circuit sensor. The Pulse Sensor may be clipped to an earlobe or a fingertip and interfaced with a microcontroller to provide heart rate measurements [11]. There are three pins on the pulse sensor, for power (VCC), ground (GND), and analogue readings (Analog Pin).

### Digital Temperature Sensor LM35

An analogue proportional response to the current temperature is generated by the LM35 temperature sensor[11]. Getting the temperature in degrees Celsius from the voltage output is easy. The lm35 is superior than the thermistor since it does not need an external calibration [11].



*Figure 3. LM35 Temperature Sensor*

### ESP8266

The ESP8266 is a cheap, 32-bit RISC micro-controller that supports Wi-Fi and has two different clock speeds (80 MHz and 160 MHz) [12]. A total of 96 KB of RAM is dedicated to storing data, while 64 KB are reserved for executing instructions [12]. The ESP8266 uses a number of patent-protected technologies to achieve very low power consumption, making it ideal for mobile, wearable, and Internet of Things applications [13]. The Esp8266 is sending data from patient sensors to the Thing speak servers as a publisher.

### Uno Arduino

As an open-source microcontroller board, the Arduino Uno is based on the Microchip AT- mega328P microprocessor[14]. The board's digital and analogue I/O pins let it to communicate with other circuits, such as expansion boards (shields) [14]. The board has 14 digital I/O pins (6 of which may be used for PWM output) and 6 analogue I/O pins, and it can be programmed using the Arduino IDE (Integrated Development Environment) through a type B USB cable[13]. It operates on voltages between 7 and 20 volts and may be fuelled by either a USB connection or an external 9-volt battery. It's a microcontroller that works similarly to the Arduino Nano and Leonardo.

### LCD

Video displays using the light-modulating properties of liquid crystals are known as liquid crystal displays (LCDs).

screen technology that uses the liquid-crystal display capabilities to show images and text [10]. An LCD display is used in conjunction with an Arduino microcontroller. Connecting the pins of an LCD display to an Arduino microcontroller allows for the display of any string of text or picture that has been programmed into the microcontroller[10].

## Programming for the System

### Arduino Software Development Environment

The Arduino Software Development Kit (IDE) is free software for creating and uploading sketches to Arduino boards.

For this reason, it is considered cross-platform [13], meaning that it may be used with a variety of computer systems. Uploading sketches to the prototype and reading data from industrial temperature sensors are both being done via the Arduino IDE.

### Thing speaks

Thing Speak is an Internet of Things (IoT) analytics application that operates in the cloud and facilitates the collection, presentation, and evaluation of streaming data [14, 15]. When your devices provide data to Thing Speak, you'll see real-time visualisations of that data. The patient's vitals are shown using Thing speak. Using the Channels and web pages that Thing Speak offers, we are able to remotely monitor and operate our system prototype. [15-18] Descriptive Technology

### Electrical Diagrams

The Pulse Sensor's output pin was connected to Arduino's A0, while the other two were connected to VCC and GND. Pin A1 of Arduino is wired to the LM35 temperature sensor's output, while VCC and GND are linked to the other two pins.

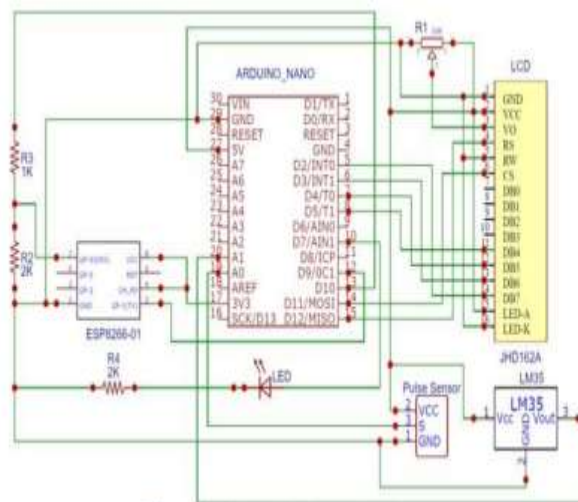

Figure 4. Circuit Schematic Diagram.

The interfacing of Pins 1,3,5,16 of LCD to GND. Hardware connection of Pin 2,15 of LCD to VCC was also done. The Pins 4,6,11,12,13,14 of LCD to Digital Pin 12,11,5,4,3,2 of Arduino. The RX pin of ESP8266 works on 3.3V and the TX pin of the ESP8266 to pin 9 of the Arduino.

## Results and Discussion

### Implementation of a Prototype

The pulse sensor and temperature sensors are shown interfaced with the ESP8266 and Arduino in Figure 5, depicting a prototype of an Internet of Things patient monitor built on these two boards. The dashboard displays sensor data that has been sent to thing talk web servers.

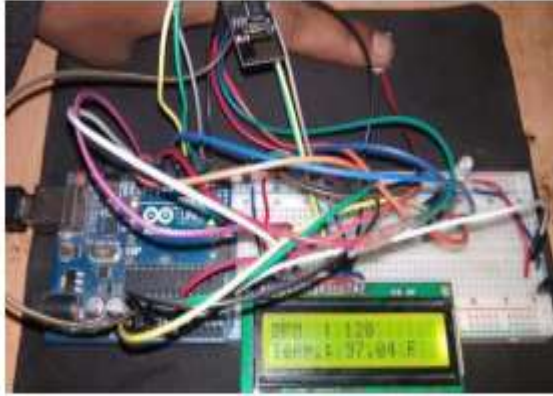

Figure 5. Implemented Prototype

## Thing Speak Web Dashboard

The ESP8266 publishes temperature and pulse rate sensor data readings to things peak servers. The things peak dashboard displays gauges for pulse rate and temperature and well as line graphs which are vital in measurement of physiological parameters for patient monitoring.

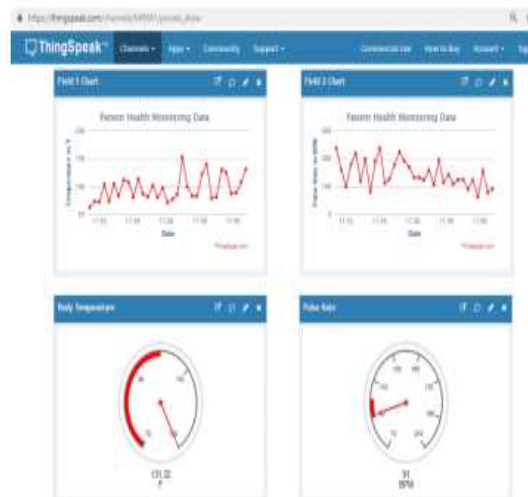

Figure 6. Thing speak web dashboard

Temperatures peaked at 150 degrees Fahrenheit, with a range of 50 to 200 degrees Fahrenheit, while the interval time ranged from 11:32 to 11:40. Clear evidence that this prototype has low enough error rates to be used in real hospitals is provided by the range of 100 to 220 in which the pulse rate typically falls.

## Conclusion

Numerous new healthcare technology companies are contributing to the rapid evolution of the IoT in the healthcare industry. Monitoring a patient's health at home or at a medical facility is a significant challenge due to the hectic nature of our everyday lives. Regular monitoring is particularly important for patients with chronic conditions. As a consequence, we provide a novel method for automating the measurement of vital signs including core temperature and heart rate in real time. Using a things peak Server, the prototype creates a smart patient health tracking system for real-time tracking of vitals including heart rate and temperature. Adding many sensors to assess oxygen and sugar levels in the blood, as well as using machine learning to analyse patient data and diagnose diseases, are all potential next steps.

## References

[1] Archip, A., Nicolae B., Elena Ş., Paul-Corneliu Hegelian, Andrei Zală, (2016). An IoT based system for remote patient monitoring, 17 th International Carpathian Control Conference (ICCC), IEEE, Slovakia. <https://doi.org/10.1109/CarpathianCC.2016.7501056>

- [2] Kumar, R., Pallikonda Rajasekaran M., (2016). An IoT based patient monitoring system using raspberry Pi, *International Conference on Computing Technologies and Intelligent Data Engineering (ICC- TIDE'16)*, IEEE, India. <https://doi.org/10.1109/ICCTIDE.2016.7725378>
- [3] Yew H.T., Ming F.N., Soh Z.P., Seng K.C., Ali C., Jamal A. D., (2018). Iot based real-time remote patient monitoring system, *16 the IEEE international colloquium on signal processing and its applications (CSPA)*, IEEE, Malaysia. <https://doi.org/10.1109/CSPA48992.2018.9068699>
- [4] Ghosh, Ananda Mohon, Debashish Halder, (2016). SK Alamgir Hossain, Remote health monitoring system through IoT, *5 the International Conference on Informatics, Electronics and Vision (ICIEV)*, IEEE, Bangladesh. <https://doi.org/10.1109/ICIEV.2016.7760135>
- [5] Jimenez, F., Romina T., (2015). Building an IoT-aware healthcare monitoring system, *34 the International Conference of the Chilean Computer Science Society (SCCC)*, IEEE, Chile. <https://doi.org/10.1109/SCCC.2015.741659>.
- [6] Krishnan, D.S.R., Gupta, S.C., Choudhury, T., (). An IoT based patient health monitoring system, *International Conference on Advances in Computing and Communication Engineering (ICACCE)*, IEEE, France. <https://doi.org/10.1109/ICACCE..8441708>
- [7] Shaikh, S., Dattatray W., Prajakta K., Vrushali K., Praffulkumar A., (2017). Patient monitoring system using IoT, *International Conference on Big Data, IoT and Data Science (BIGD)*, IEEE, <https://doi.org/10.1109/BID.2017.8336594>
- [8] Banerjee, S., Subhajt R., (2016). Design of A Photo Plethysmography Based Pulse Rate Detector, *International Journal of Recent Technology and Engineering*, 2, 302-306.
- [9] Sarmah, S.S., (2018). An efficient IoT-based patient monitoring and heart disease prediction system using deep learning modified neural network, *IEEE Access*, 8 135784- 135797. <https://doi.org/10.1109/ACCESS.2018.3007561>
- [10] Yew, H.T., Ng, M.F., Ping, S. Z., Chung, S.K., Chekima, A., Dargham, J.A., (2018) IoT Based Real-Time Remote Patient Monitoring System, *16 th IEEE International Colloquium on Signal Processing and Its Applications (CSPA)*, IEEE, Malaysia. <https://doi.org/10.1109/CSPA48992.2018.9068699>
- [11] Rahman, A., Rahman, T., Ghani, N.H., Hossain S., Ud- din, J., (2018) IoT Based Patient Monitoring System Using ECG Sensor, *International Conference on Robotics, Electrical and Signal Processing Techniques (ICREST)*, IEEE, Bangladesh. <https://doi.org/10.1109/ICREST.2019.8644065>
- [12] Gabriel, M.M., Kamweru P.K., (2018). Arduino uno, ultrasonic sensor HC-SR04 motion detector with display of distance in the LCD, *International Journal of Engineering Research and Technical Research*, 9(5), 936- 942. <http://dx.doi.org/10.17577/IJERTV9IS050677>
- [13] Saravanan, S., Kalaiyarsi, M., Karunanithi, K., Karthi, S., Pragaspathy, S., Kadali, K. S. (2018). Iot Based Healthcare System for Patient Monitoring, *In IoT and Analytics for Sensor Networks*, Springer, Singapore. [https://doi.org/10.1007/978-981-16-2919-8\\_40](https://doi.org/10.1007/978-981-16-2919-8_40)
- [14] IoT Based Patient Health Monitoring using ESP8266 & Arduino, <https://how2electronics.com/iot-patient-health-monitoring-system-esp8266/>
- [15] ESP8266. Available online: <http://espressif.com/esp8266ex/>
- [16] Fezari, M., Ali Al Dahoud, (). *Integrated Development Envi- ronment "IDE" For Arduino, WSN applications*, 1-12.
- [17] Badamasi, Yusuf Abdullahi, (2014). The working principle of an Arduino, *11th international conference on electronics, computer and com- putation (ICECCO)*, IEEE, Nigeria. <https://doi.org/10.1109/ICECCO.2014.6997578>.